

DE

EN

NL

FR

IT

ES

PL

CS

SV

**DHOME**  
**PILOT**

# Kurzanleitung

Garagentorantrieb



premium smart



classic





## Sicherheitshinweise

Bitte die Sicherheitshinweise vor der Montage beachten!



**Lebensgefahr durch Stromschlag**



**Gefahrenstelle / gefährliche Situation**



**GEFAHR!**

Diese Gefährdung wird zu schweren Verletzungen oder zum Tode führen.



**WARNUNG!**

Diese Gefährdung kann zu schweren Verletzungen oder zum Tode führen.



**VORSICHT!**

Diese Gefährdung kann zu geringfügigen bis mittelschweren Verletzungen führen.



**ACHTUNG!**

Diese Gefährdung kann zu Sachschäden führen.

Diese Kurzanleitung ist nur ein Bestandteil des kompletten Benutzerhandbuchs. Für eine sichere Handhabung des Produktes ist es erforderlich, das gesamte Handbuch zu lesen. Dieses ist auf unserer Homepage verfügbar:

<https://service.homepilot-smarthome.com>



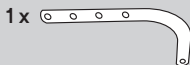
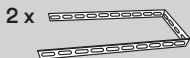
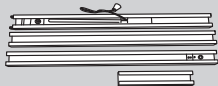
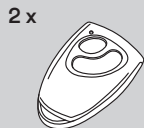
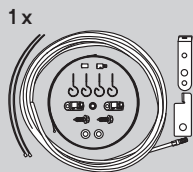
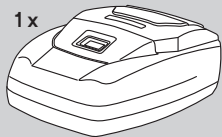

classic:



premium smart:

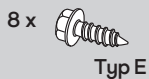
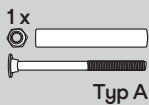
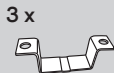
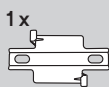
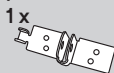

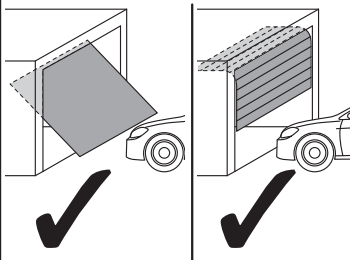
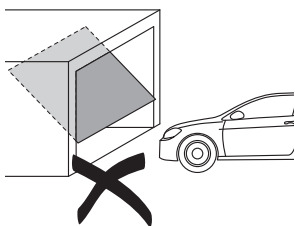
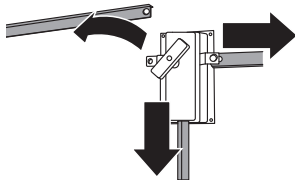
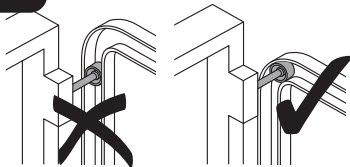
**i****i****1****2****ACHTUNG!**

Die alten Torverriegelungen aufbewahren, um den Originalzustand des Tores wieder herstellen zu können.

**ACHTUNG!**

Bei Sektionaltoren muss im geschlossenem Zustand die Führungsrolle des oberen Torsegmentes im Bogen der Führungsschiene stehen.

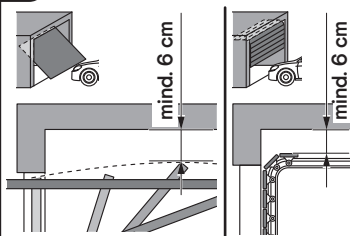
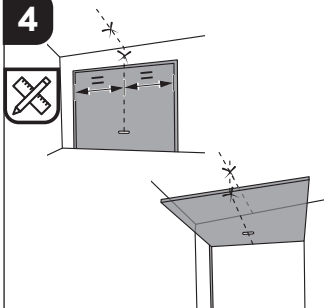
**3****4**

5

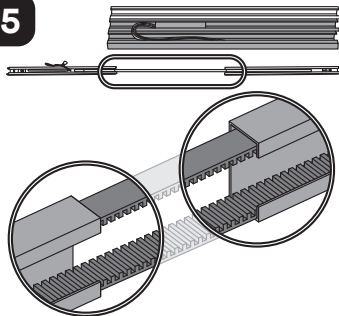

6

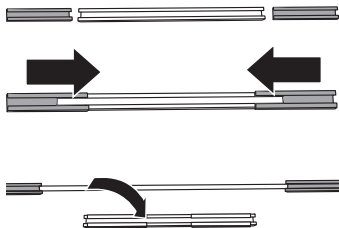

7

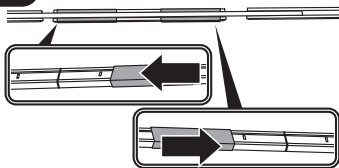

8

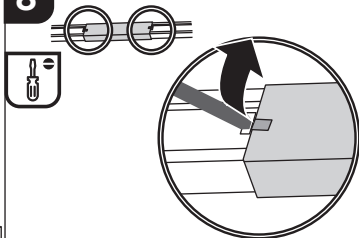
**ACHTUNG!**

Die beiden Verbinder jeweils mittig zwischen die Fixierungsbleche der Schienenunterseite legen!

9

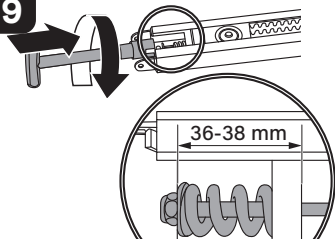

10

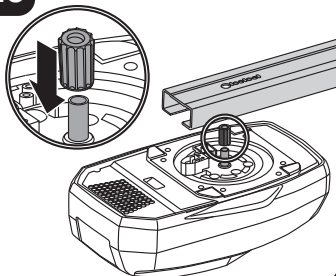
**ATTENTION!**

Den Zahnriemen nicht zu straff spannen!

11

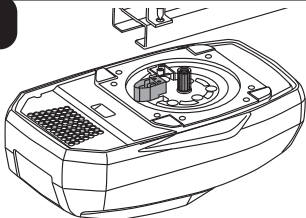
**ACHTUNG!**

Den Mikroschalter beim Befestigen der Schiene am Antriebsgehäuse nicht beschädigen!

12

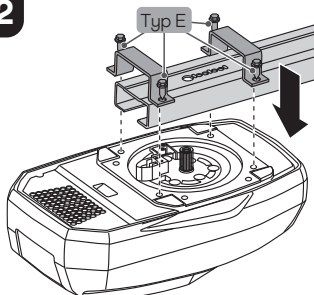

13

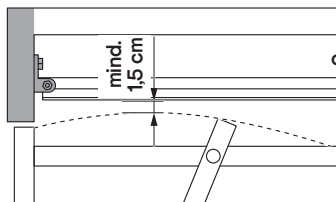

mind.  
1,5 cm

oder

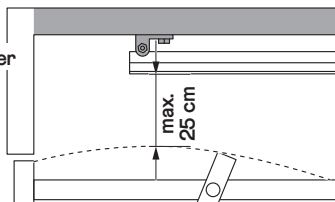

max.  
25 cm

14

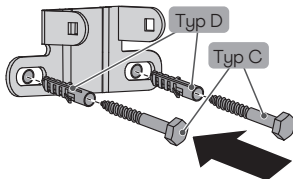
**ACHTUNG!**

Den Sturzwinkel mittig zum Tor montieren!

15

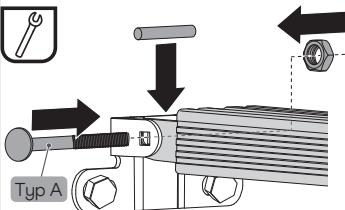

Typ A

16

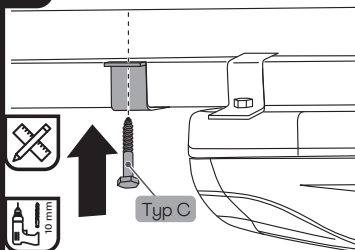

17

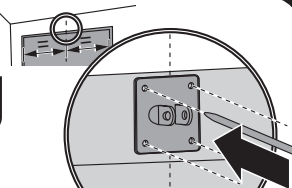
**ACHTUNG!**

Den Torwinkel vorzugsweise am Torrahmen befestigen! Für Kunststoff- oder dünnwandige Holz-tore sind u. U. zusätzliche Verstrebungen nötig um eine Beschädigung des Tores zu vermeiden.

18

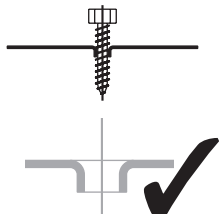
**ACHTUNG!**

Den mitgelieferten Schlagdorn verwenden, da Schrauben bei gebohrten Löchern nicht genug Halt haben.

19

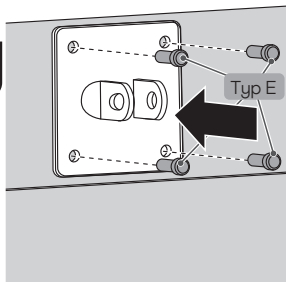

20

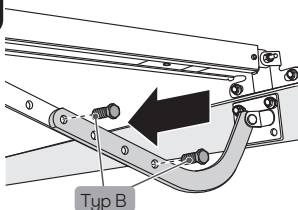

21

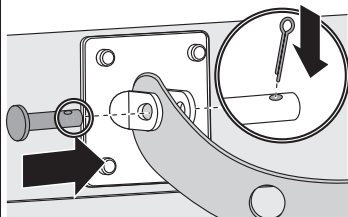

22

## Deckenmontage



mit Mittenabhängung

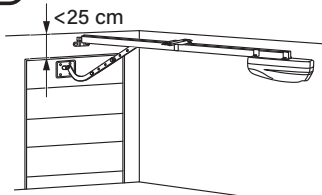

mit Lochbandwinkel

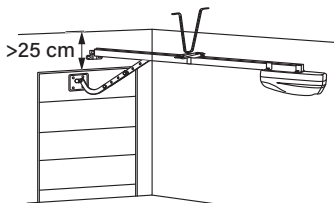

23

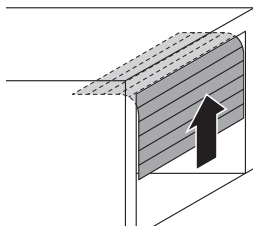
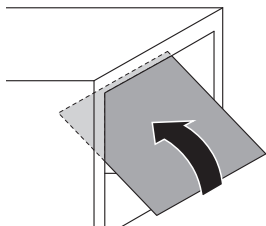
**ACHTUNG!**

Das Tor vorsichtig öffnen bis zum Einrasten des Schlitten.

24

**ACHTUNG!****Durch unsachgemäßen Gebrauch besteht erhöhte Verletzungsgefahr!**

- Warnaufkleber bezüglich Einklemmgefahren dauerhaft an einem gut sichtbaren Ort oder in der Nähe der installierten Steuerungen befestigen.
- Das Etikett für manuelle Entriegelung dauerhaft neben dem Bedienelement befestigen.
- Alle Warnaufkleber-Schilder so anbringen, dass sie gut lesbar sind.

25

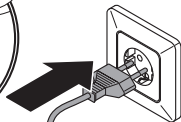
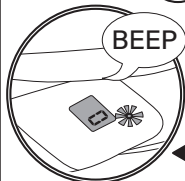
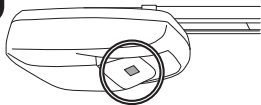



**A1**

Endpunkteinstellung

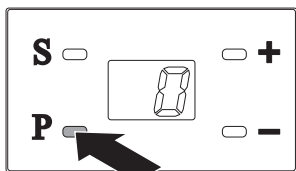

5 sec.

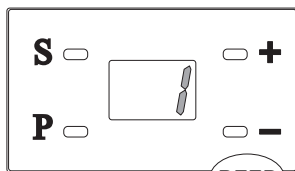
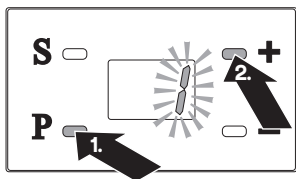
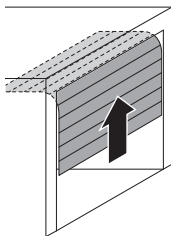
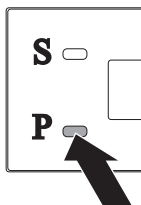
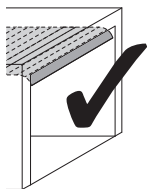
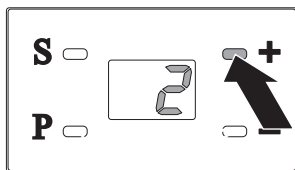
**A2****A3****A4****A5****A6**

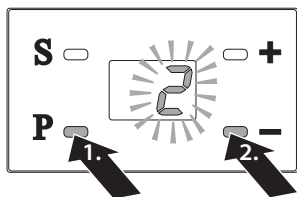
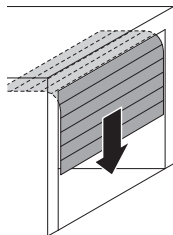
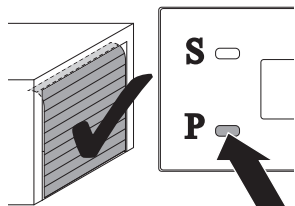
**A7****A8****A9****A10****ACHTUNG!**

- Die falsche Reihenfolge bei der Einstellung der Endpunkte führt zu Fehlfunktionen, bitte daher unbedingt die vorgegebene Einstellreihenfolge einhalten.
- Erst mit der Einstellung der beiden Endpunkte sowie der Referenzfahrt zur Kraftmessung sind die erforderlichen Grundeinstellungen zum sicheren Betrieb erfüllt.
- Damit die Grundeinstellungen korrekt gespeichert werden, immer nach jeder vorgenommenen Einstellung „Programmierung abschließen“ (#A16).

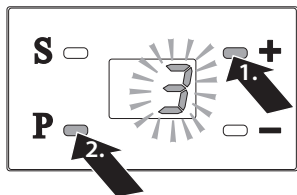
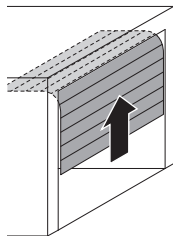
**A11** Referenzfahrt durchführen**A12**

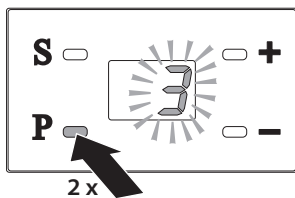
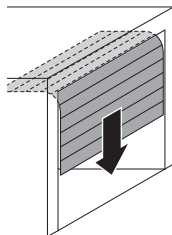
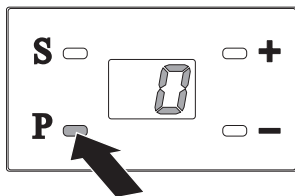
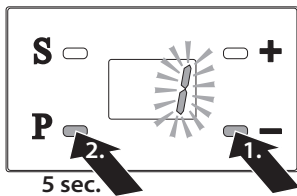
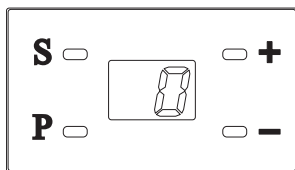
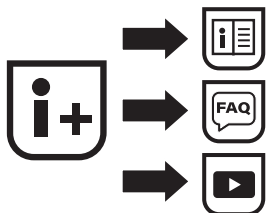
**A13****A14****A15****A16** Programmierung abschließen**A17****A18**

# **HOME PILOT**

## **KONTAKT**

- via E-Mail: [service.de@homepilot-smarthome.com](mailto:service.de@homepilot-smarthome.com)  
[service.at@homepilot-smarthome.com](mailto:service.at@homepilot-smarthome.com)  
[service.ch@homepilot-smarthome.com](mailto:service.ch@homepilot-smarthome.com)

**RADEMACHER**  
Geräte-Elektronik GmbH  
Buschkamp 7  
46414 Rhede (Germany)