



**ENGLISH** - *LED traffic light with two lights*  
**ITALIANO** - *Semaforo a LED a due luci*  
**DEUTSCH** - *Ampel mit zwei LED lichten*  
**ESPAÑOL** - *Semáforo con LED con dos luces*  
**FRANCAIS** - *Feux à LED avec deux lumières*

**CE**

Instruction - Istruzioni - Anleitungen - Instrucciones



### **(EN) TECHNICAL DATA SHEET**

Power supply: **min 8 V dc / 9 V ac - max 45 V dc / 35 V ac**

Weight: **1,95 Kg**

Lens color: **Red, Green, Yellow.**

Lamp consume: **3 w**

Middle life lamp: **100.000 hours**

Degree of protection: **IP 65**

### **(IT) CARATTERISTICHE TECNICHE**

Alimentazione elettrica: **min 8 V dc / 9 V ac - max 45 V dc / 35 V ac**

Peso: **1,95 Kg**

Colore lenti: **Rosso, Verde, Giallo**

Consumo lampada: **3 w**

Durata media lampada: **100.000 ore**

Grado di protezione: **IP 65**

### **(DE) TECHNISCHE EIGENSCHAFTEN**

Alimentazione elettrica: **min 8 V dc / 9 V ac - max 45 V dc / 35 V ac**

Gewicht: **1,95 Kg**

Farbe langsam: **Rot, Grün, Gelb**

Verbrauche Lampe: **3 w**

Leben vermittelt Lampe: **100.000 Stunden**

Maß an Schutz: **IP 65**

### **(FR) CARACTERISTIQUES TECHNIQUES**

Alimentazione elettrica: **min 8 V dc / 9 V ac - max 45 V dc / 35 V ac**

Poids: **1,95 Kg**

Couleur verres: **Rouge, Vert, Jaune**

Consommation lampe: **3 w**

Durée moyenne lampe: **100.000 heures**

Degré de protection: **IP 65**

### **(ES) CARACTERÍSTICAS TÉCNICAS**

Alimentazione elettrica: **min 8 V dc / 9 V ac - max 45 V dc / 35 V ac**

Peso: **1,95 Kg**

Color lente: **Rojo, Verde, Amarillo**

Consumo lámpara: **3 w**

Vida mediana lámpara: **100.000 horas**

Grado de protección: **IP 65**

**HTC INFISSI di Di Campli Livia**

Via Villa Selciaroli, 112/A - 66014 Crecchio (CH)

Tel. +39 0871 478022 - Fax +39 0871 478021

**(EN) DIMENSIONS**  
**(IT) DIMENSIONI**  
**(DE) DIMENSIONEN**  
**(FR) DIMENSIONS**  
**(ES) DIMENSIONES**

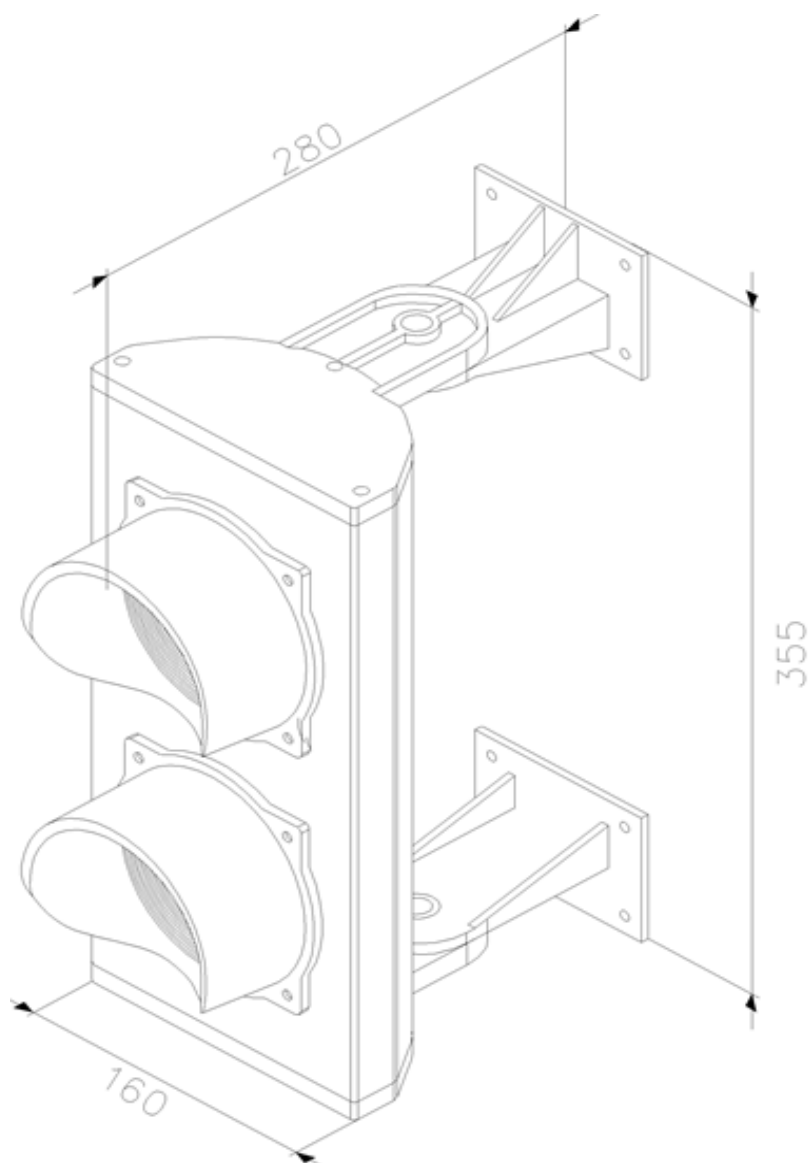

**HTC INFISSI di Di Campli Livia**  
Via Villa Selciaroli, 112/A - 66014 Crecchio (CH)  
Tel. +39 0871 478022 - Fax +39 0871 478021

**SCHEMA DI ASSEMBLAGGIO  
SCHEDULE OF ASSEMBLY**

LEGENDA	
1	Corpo semaforo 2 luci
2	Tappo semaforo
3	Staffa fissaggio semaforo
4	Separatore luci
5	Scheda led - rosso
6	Scheda led - verde
7	Guarnizione tappo semaforo
8	Lente rossa / verde
9	Guarnizione lente
10	Coprilente
11	Dado autobloccante M8
12	Vite TCEI m8x25

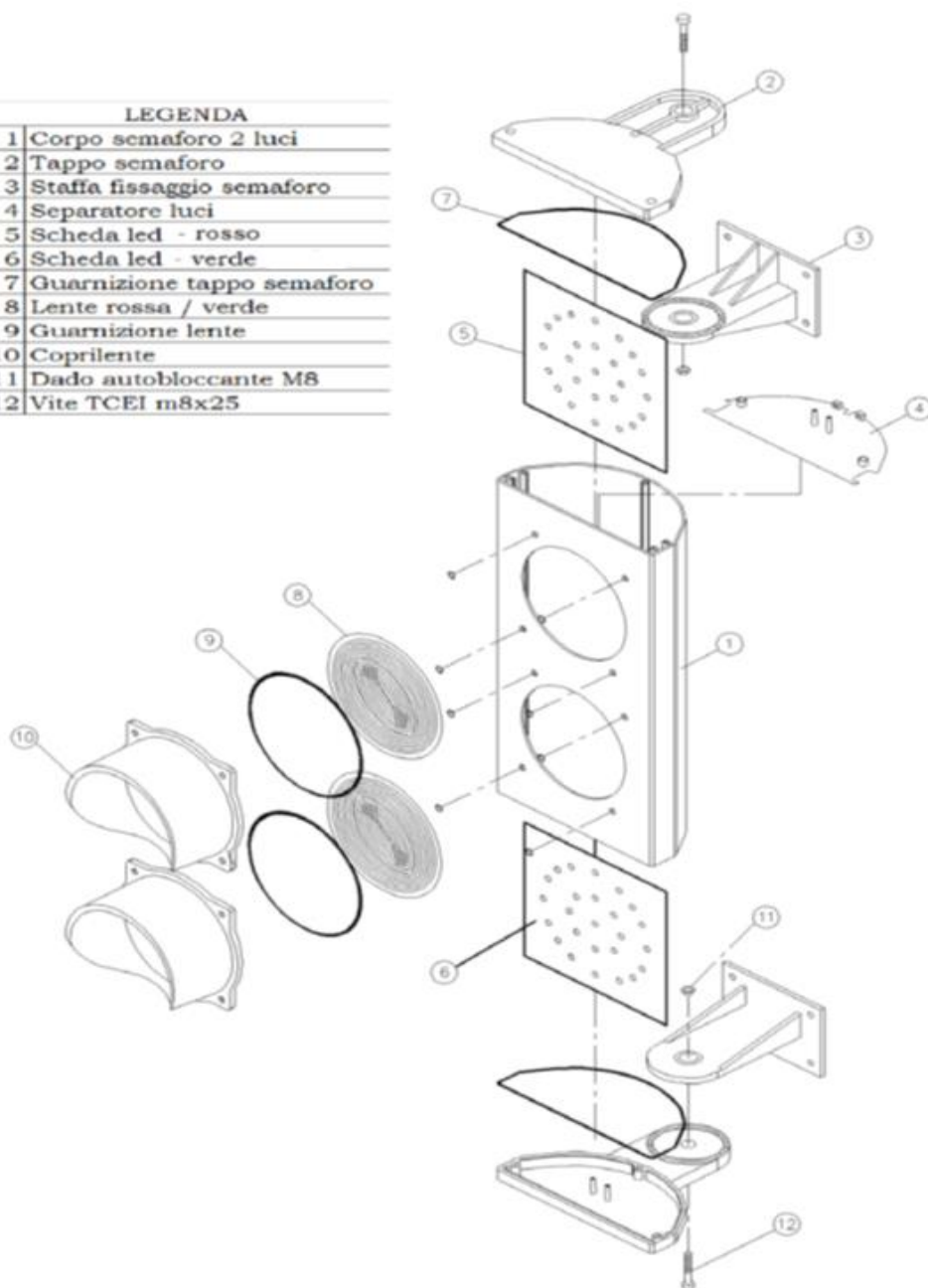

**HTC INFISSI di Di Campli Livia**

Via Villa Selciaroli, 112/A - 66014 Crecchio (CH)

Tel. +39 0871 478022 - Fax +39 0871 478021

**SCHEMA ELETTRICO  
ELECTRICAL DIAGRAM**

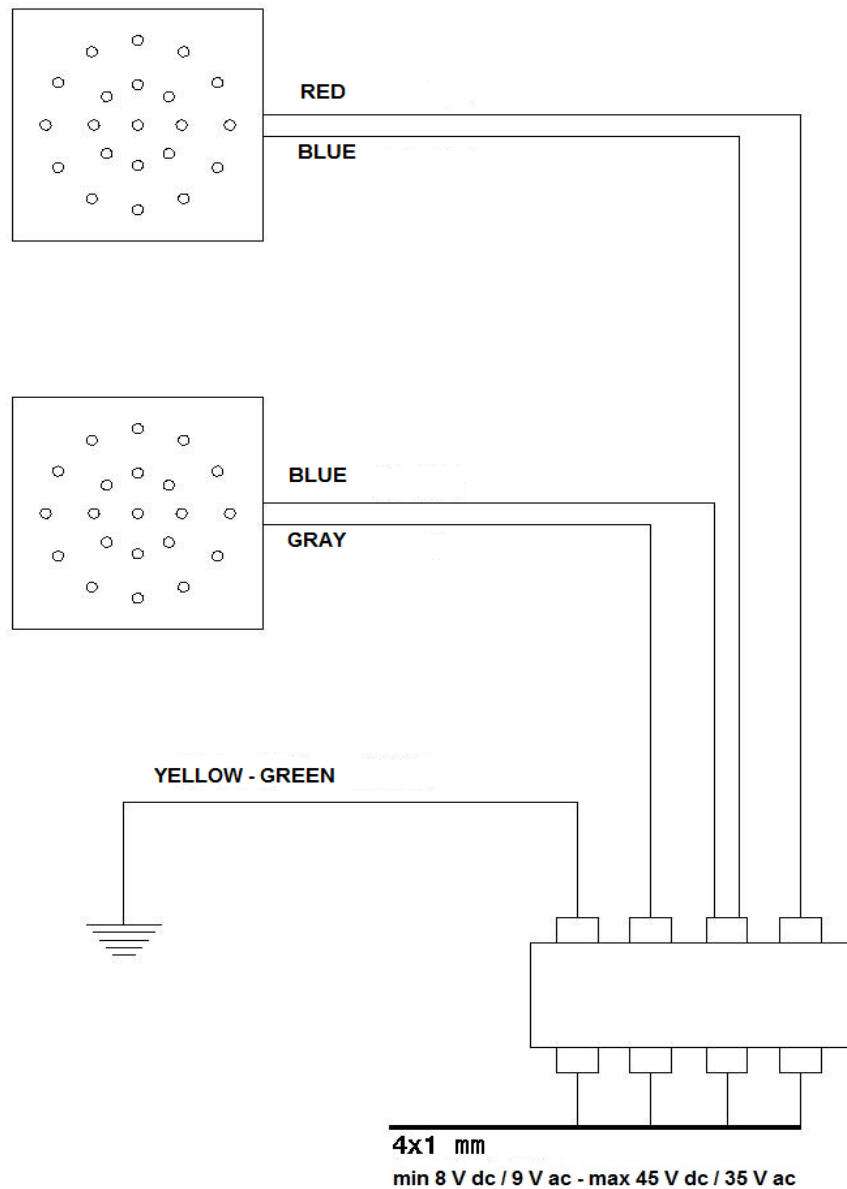

**HTC INFISSI di Di Campi Livia**  
Via Villa Selciaroli, 112/A - 66014 Crecchio (CH)  
Tel. +39 0871 478022 - Fax +39 0871 478021

**(EN) ASSEMBLY POSITIONS**  
**(IT) POSIZIONI DI MONTAGGIO**  
**(DE) POSITIONIERST VON MONTAGE**  
**(FR) POSITIONS D'ASSEMBLAGE**  
**(ES) POSICIONES DE MONTAJE**

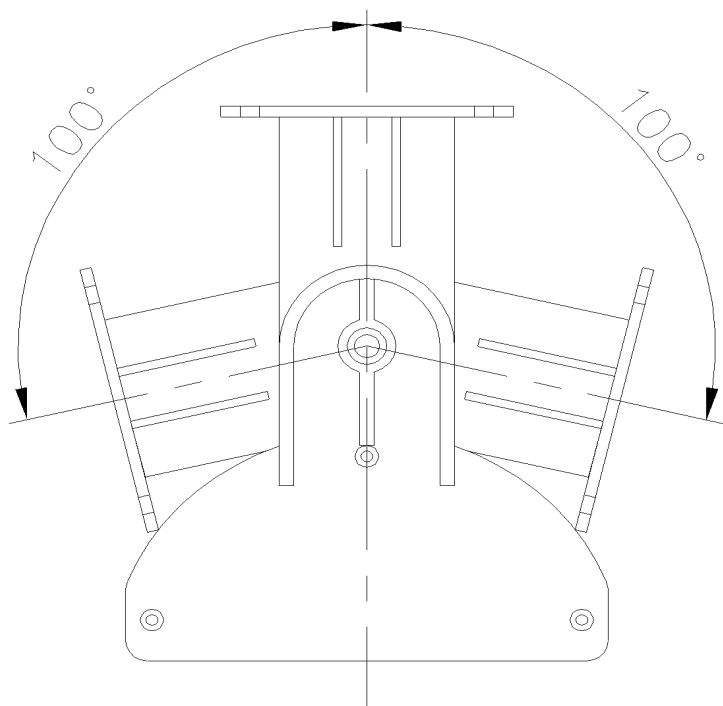

**HTC INFISSI di Di Campli Livia**  
Via Villa Selciaroli, 112/A - 66014 Crecchio (CH)  
Tel. +39 0871 478022 - Fax +39 0871 478021

**(EN) ATTENTION!**

- Before connecting the electrical cables make sure that the power supply is off.
- The traffic lights have to be installed by qualified technical staff only.
- Used vacuum cleaners still contain many recyclable materials. Therefore please take used vacuum cleaners to your retailer or recycling center so that they can be recycled.

**(IT) ATTENZIONE!**

Prima di effettuare i collegamenti assicurarsi che l'alimentazione sia staccata. L'installazione deve essere effettuata da personale qualificato. Gli apparecchi dismessi contengono materiali preziosi. Si consiglia pertanto di restituire l'apparecchio dismesso al proprio rivenditore o presso centro di riciclaggio.

**(DE) ACHTUNG!**

Bevor Sie die Ampel berühren, versichern Sie sich dass die Spannung ausgeschaltet ist.

Die Installation darf nur von einem Fachmann ausgeführt werden. Altgeräte enthalten vielfach noch wertvolle Materialien. Geben Sie deshalb Ihr ausgedientes Gerät bei Ihrem Händler bzw. einem Recyclingcenter zur Wiederverwertung ab.

**(FR) ATTENTION!**

Avant d'effectuer les branchements électriques s'assurer que l'alimentation soit débranchée.

L'installation ne doit être effectuée que par du personnel qualifié. Les appareils usagés contiennent souvent des matériaux précieux. Remettez donc votre appareil usagé à votre revendeur ou à un centre de recyclage pour la revalorisation.

**(ES) ATENCIÓN!**

Antes de intervenir sobre el dispositivo asegurarse de que la alimentación esté desconectada.

La instalación debe ser efectuada para personal cualificado. Los aparatos usados contienen aún muchos materiales valiosos. Por este motivo entregar los aparatos usados en el comercio habitual o en el centro de reciclaje para su reaprovechamiento.

**HTC INFISSI di Di Campli Livia**

Via Villa Selciaroli, 112/A - 66014 Crecchio (CH)

Tel. +39 0871 478022 - Fax +39 0871 478021



**HTC INFISSI di Di Campli Livia**

Via Villa Selciaroli, 112/A - 66014 Crecchio (CH)

Tel. +39 0871 478022 - Fax +39 0871 478021